

FreeSpan Straight Rail

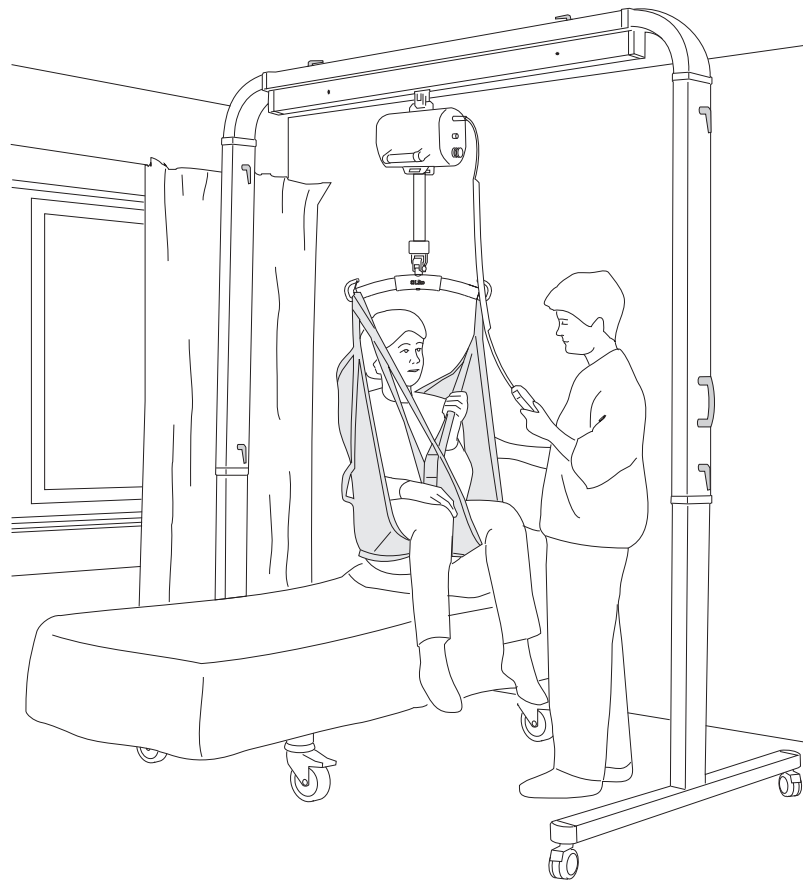

Instruction Guide



Product Description

FreeSpan SR is a freestanding lift system that is intended for use with Liko's Multirall or Likorall lift units. It consists of three main components that can be assembled without tools. The lift motor is mounted in the pre-fitted carriage.

FreeSpan is adjustable to four different heights and is available in 8 different rail lengths, giving it a width range of 2 to 5.5 metres (6' 8" - 18' 4").

Equipped with locking handles on the rail, FreeSpan can be widened a further 225 mm (8.9 in.) in each corner.

FreeSpan can be lowered to the transport position (1700 mm/66.9 in.) to simplify mounting of the lift unit and/or moving the lift system to another room.

FreeSpan SR has lockable pivoting wheels, is made of aluminium, and despite its light weight, it is extremely stable. FreeSpan complies with EN ISO 10535 and the medical devices directive MDD 93/42/EEC.

△ is a warning triangle used for situations that demand extra care and attention.

In this document, the person being lifted is referred to as the "patient" and the person helping is referred to as the "caregiver".

IMPORTANT!

Carefully read instructions for the lift and lifting accessories before use. Lifting and transferring a person always presents a potential risk. A thorough understanding of the contents of this instruction guide is essential. Only trained personnel should use the equipment. If you have questions, please contact Hill-Rom or your local Hill-Rom representative.

Contents

Safety Instructions.....	2
Definitions	3
Lift Unit.....	3
Technical Data/Measurements.....	4
Assembly Instructions	5-6
User's Guide	7
Care and Maintenance	8

△ NOTE! This instruction guide contains information that is important for users of the product. A complete understanding of the contents of the instruction guide is essential, and only personnel who are well informed should use the equipment. Remember to keep the instruction guide readily accessible for users of the product.

Safety Instructions

△ Before use, ensure that:

- the lift is assembled according to the instructions
- the frame of the lift is assembled and adjusted to working height (2250-2550 mm/88.6-100.4 in.)
- lifting accessories are correctly applied to the lift
- you have read and understood the instruction guides for the lift and lifting accessories
- personnel using the equipment have received appropriate instructions and training
- the lifting accessories are not damaged
- you have selected the correct type, size, material, and design of slings and accessories to safely meet the patient's needs
- the lifting accessory is correctly and securely applied to the patient, so that no personal injury can occur.

△ Never leave a patient unattended in FreeSpan!

FreeSpan SR complies with the requirements of EN ISO 10535.

Maximum load: 200 kg (440 lbs.), 230 kg (507 lbs.) or 250 kg (550 lbs.), depending on the length of the rail and which lift unit that is used (see page 4).

Definitions

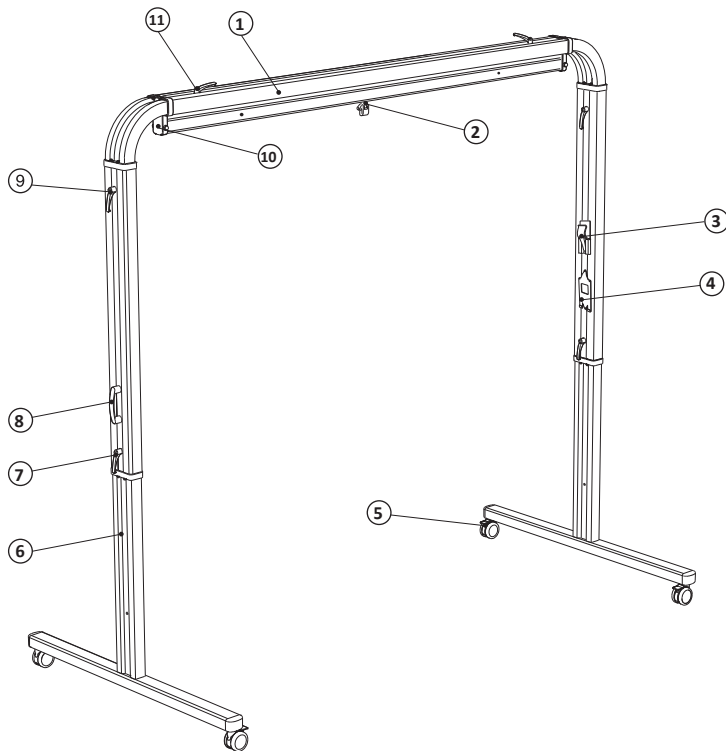

1. Rail with corners
2. Carriage (single- or two-piece)
3. Parking bracket
4. Charger plate
5. Pivot wheels with brakes
6. Side support, telescopic
7. Lower locking handle
8. Handle
9. Upper locking handle
10. End-stops
11. Locking handle for adjusting corners

△ NOTE! The locking handles for adjusting corners should never be dismounted.

Lift Unit

FreeSpan is intended for use with Multirall or Likorall lift units.
For appropriate accessories, see the instruction guides for respective lift unit.

Installation of Multirall lift units on FreeSpan is described in the Multirall instruction guide.

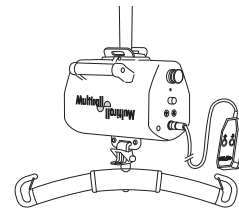

Installation of Likorall lift units on FreeSpan is described in this instruction guide.

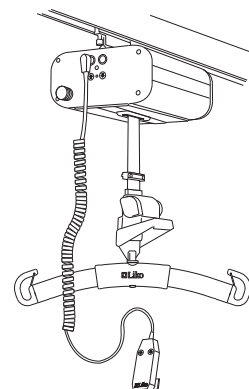

Technical Data/Measurements

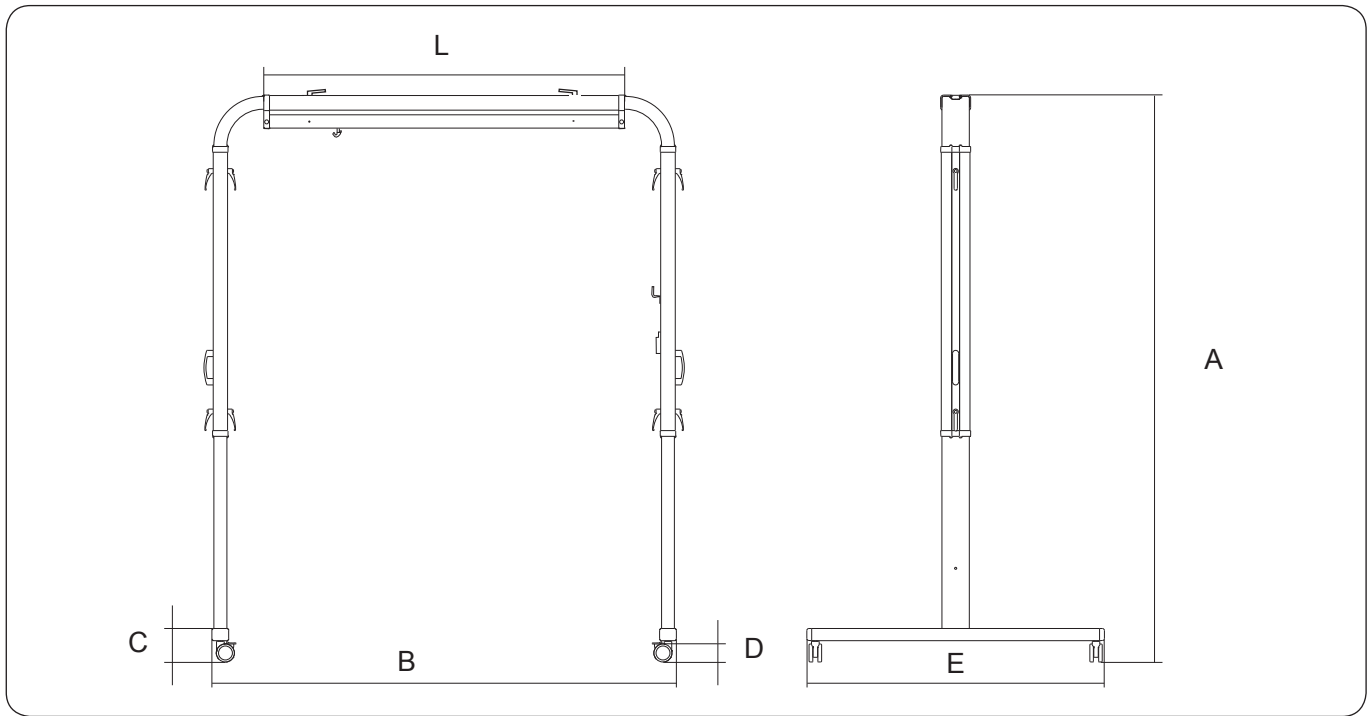

Model	Maximum load ¹	L	A*	A _{min} **	B	C	D	E	Weight	
									total	part***
15	250	1500	2250-2550	1700	1990-2440	135	75	1240	41.5	15.7
20	250	2000	2250-2550	1700	2490-2940	135	75	1240	44.3	18.5
25	250	2500	2250-2550	1700	2990-3440	135	75	1240	47.1	21.3
30	250	3000	2250-2550	1700	3490-3940	135	75	1240	50.0	24.2
35	250	3500	2250-2550	1700	3990-4440	135	75	1240	52.8	27.0
40	230	4000	2250-2550	1700	4490-4940	135	75	1240	55.6	29.8
45	200	4500	2250-2550	1700	4990-5440	135	75	1240	58.4	32.6
50	200	5000	2250-2550	1700	5490-5940	135	75	1240	61.3	35.5

Maximum load and weight in kg. Measurements in mm.

¹ Note that the length of the rail is the determining factor for the maximum load of the FreeSpan system, see marking on the rail!

* The heights of the FreeSpan system is adjustable at intervals of 100 mm.

** Note that the lowest working height for FreeSpan is 2250 mm. The 1700 mm height is intended only for transport, not for lifting or transferring patients.

*** The weight is for the single most heavy part of the FreeSpan system when it is dismantled.

Model	Maximum load ¹	L	A*	A _{min} **	B	C	D	E	Weight	
									total	part***
15	551	59.1	88.6-100.4	66.9	78.3-96.1	5.31	2.95	48.8	91.5	34.6
20	551	78.7	88.6-100.4	66.9	98.0-115.7	5.31	2.95	48.8	97.7	40.8
25	551	98.4	88.6-100.4	66.9	117.7-135.4	5.31	2.95	48.8	103.8	47.0
30	551	118.1	88.6-100.4	66.9	137.4-155.1	5.31	2.95	48.8	110.2	53.4
35	551	137.8	88.6-100.4	66.9	157.1-174.8	5.31	2.95	48.8	116.4	59.5
40	507	157.5	88.6-100.4	66.9	176.8-194.5	5.31	2.95	48.8	122.6	65.7
45	441	177.2	88.6-100.4	66.9	196.5-214.2	5.31	2.95	48.8	128.7	71.9
50	441	196.9	88.6-100.4	66.9	216.1-233.9	5.31	2.95	48.8	135.1	78.3

Maximum load and weight in lbs. Measurements in inches.

¹ Note that the length of the rail is the determining factor for the maximum load of the FreeSpan system, see marking on the rail!

* The heights of the FreeSpan system is adjustable at intervals of 3.94 in.

** Note that the lowest working height for FreeSpan is 88.6 in. The 66.9 in. height is intended only for transport, not for lifting or transferring patients.

*** The weight is for the single most heavy part of the FreeSpan system when it is dismantled.

Assembly Instructions

Before assembly, check that the following components are included:

- Side support (2 pcs) with wheels, handles, locking handles, parking bracket and charger plate
- Rail with corners, end-stops, carriage and locking handles
- 2 pcs K6S M4x10 screw
- 2 pcs M8x25 bolt, 2 pcs M8 nut

Before assembly, ensure that the side supports are locked in their lowest position and that the upper locking handles have been removed from both side supports.

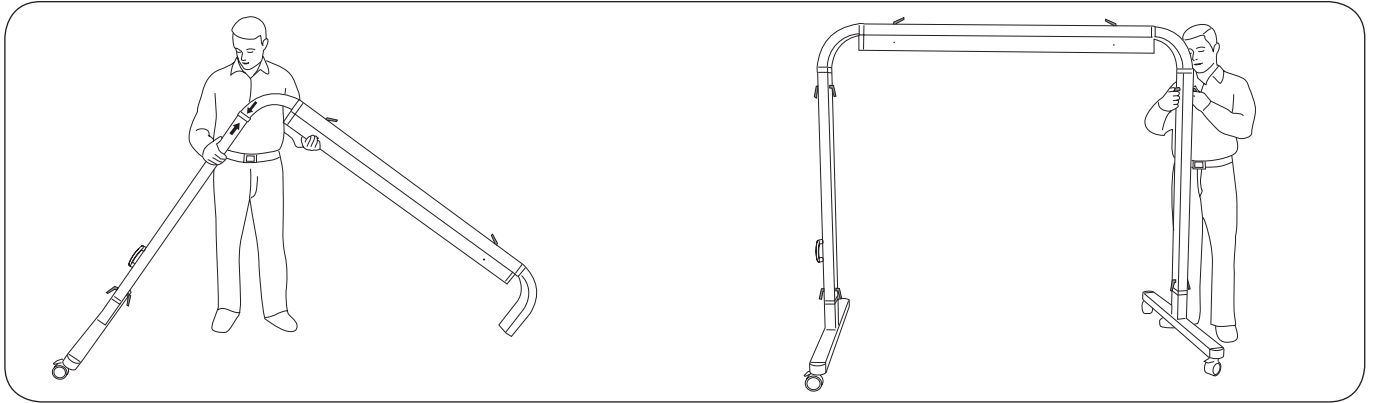

1. Fit the rail to one of the side supports, as in the illustration. Make sure the handle is facing outward. Mount the upper locking handle that holds the rail to the side support, and tighten.

△ Note that the upper locking handles lock the rail to the side supports and may only be used when assembling or disassembling FreeSpan, not when adjusting the heights!

2. Repeat the above procedure with the other side support. Make sure the handles are aligned lengthwise with the side supports.

3. Adjustment of overall width

If you need to adjust the width of FreeSpan: Loosen the locking handles on top of the rail and pull the side supports out to the desired width (max 225 mm/8.9 in. wider in each corner). Tighten the locking handles.

△ NOTE! The locking handles for adjusting corners must not be dismantled from the rail.

4. Mount the lift unit in the pre-mounted carriage. Note that FreeSpan is delivered with a carriage specific for either Likorall or Multirall lift units. Follow the instructions, below. For mounting with Multirall, see the instruction in the Multirall instruction guide.

△ Read the instruction guide for the lift unit you are using!

Mounting Likorall lift unit

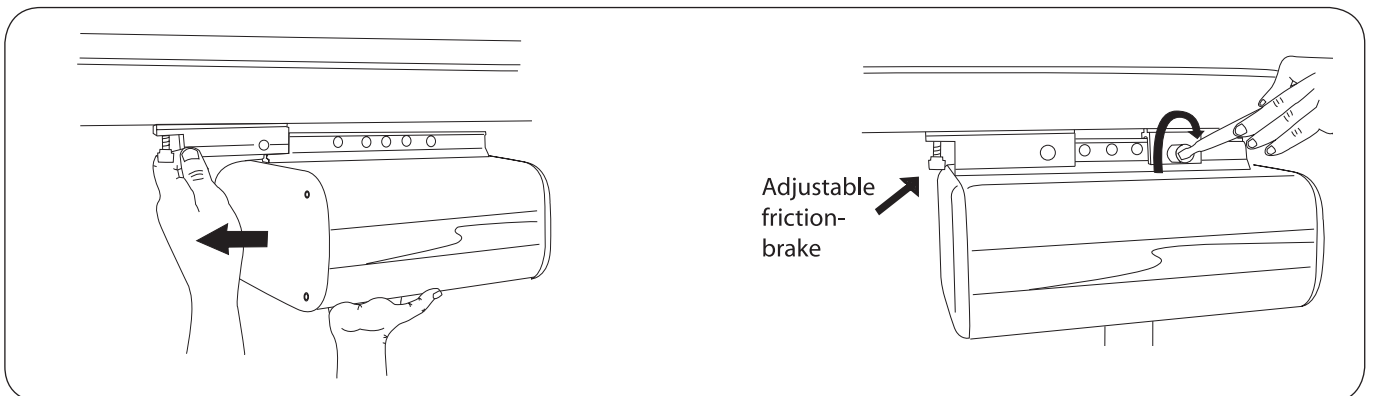

Slide the lift unit onto the longer carriage with the emergency stop end in the opposite direction as the carriage brake knob, as in the illustration above. Affix the carriage in the outermost hole in the mounting rail above the lift unit using the accompanying bolt (M8x25) and nut (M8).

Then, slide on the shorter carriage from the other direction. Affix the carriage in the outermost hole in the mounting rail above the lift unit using the accompanying bolt (M8x25) and nut (M8).



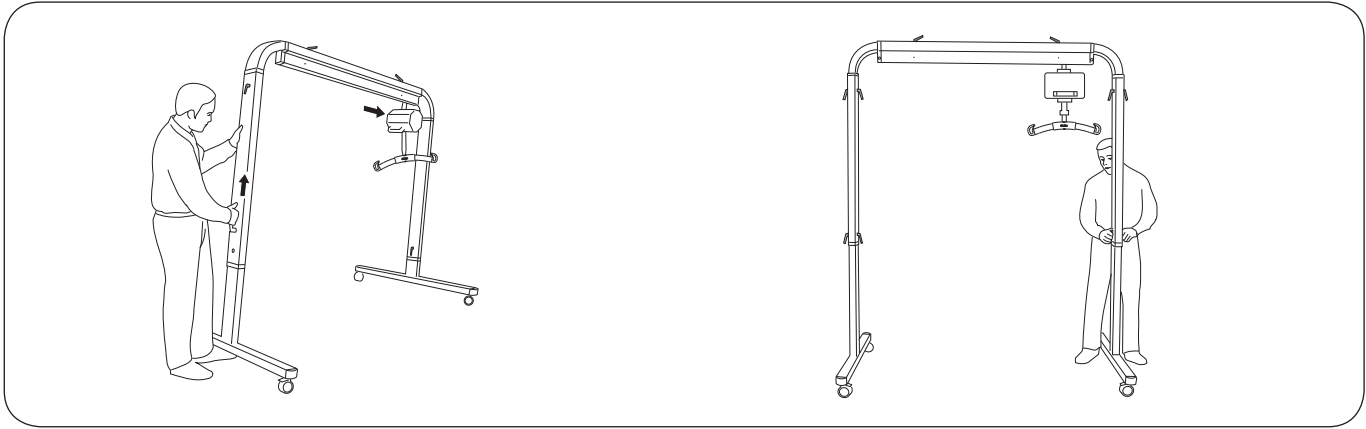

5. Now FreeSpan is ready to be raised to the correct height. There are four different height positions.

△ Note that the lift unit slides freely on the rail. Therefore, move the lift unit away from the side support that you intend to raise first.

Start by removing the lower locking handle. Lift the handle to the desired rail height (max total height 2550 mm/100.4 in.). Insert the locking handle in the appropriate hole and tighten. Repeat this procedure with the other side support.

Mounting the charger

The battery charger for Likorall and Multirall can be mounted on the charger plate, which is placed on the side support.

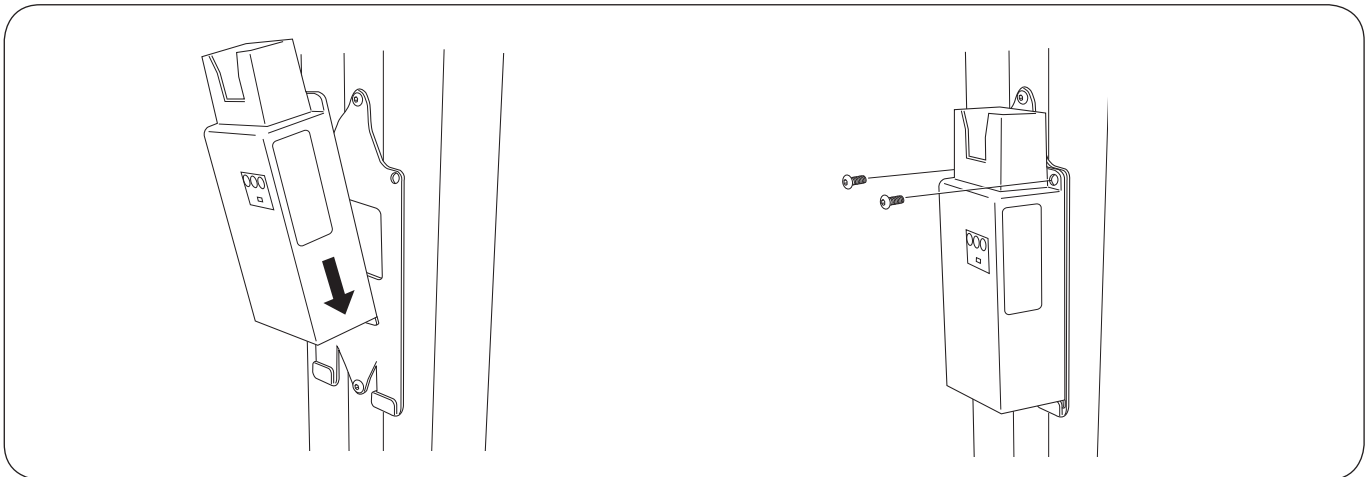

Hook on the lower part of the charger on the pre-mounted charger plate (as illustrated).

Fasten the charger on the charger plate with the two accompanying screws (K6S M4x10).

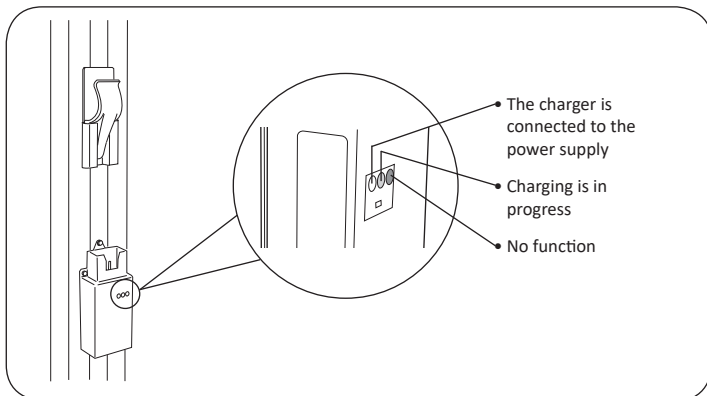

Now the charger is ready for use.

User's Guide

During use and during lifting operations, FreeSpan should be positioned so that the rail always is directly over the patient's centre of gravity. Lifting at any angle away from the rail will affect stability negatively. In the case of lifting a patient from a bed, this means that the rail should be aligned directly over the bed. This applies both to transfers from the bed to the bed-side and to a position near the foot of the bed.



Moving FreeSpan

FreeSpan can be moved when fully assembled with the lift unit, though not with the patient in the lift. Release wheel locks and move FreeSpan to the desired location. If the lift is to be moved from one room to another and the door opening is too low, FreeSpan can be lowered to its transport position (1700 mm/66.9 in.). We recommend that two people move the lift system.

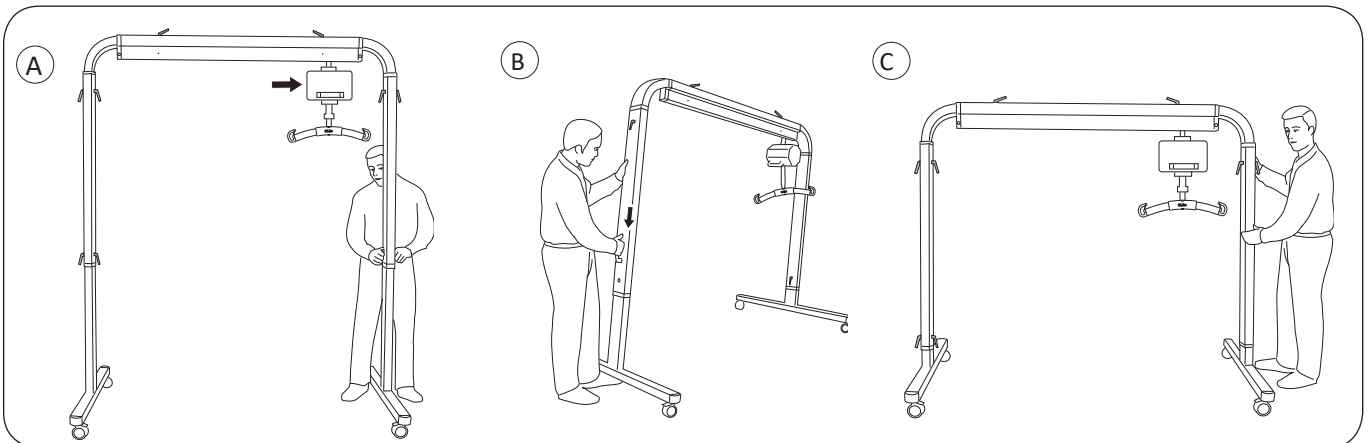

A) Start by moving the lift unit to the side that is to be lowered first. Loosen the locking handle, remove it and lower the side support to the lowest position. Hold the handle firmly to maintain a secure grip.

B-C) Repeat this procedure with the other side support.

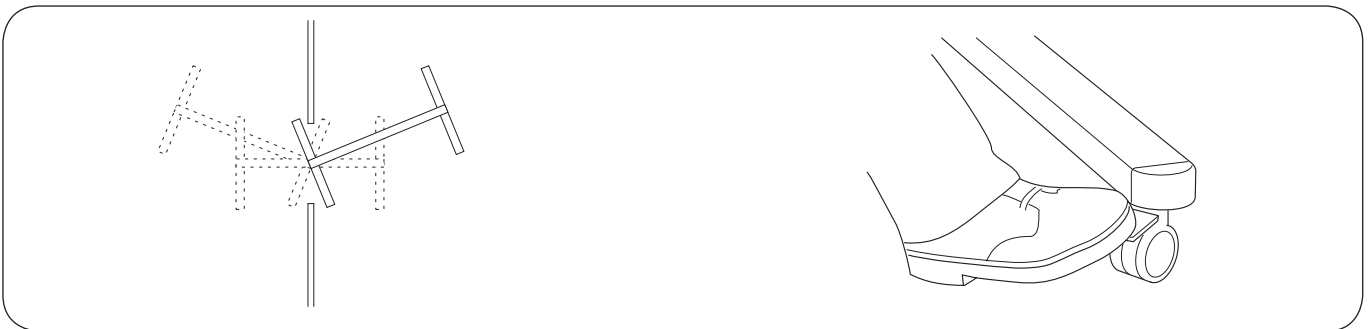

Helpful hint. Where door openings are narrower than 1240 mm (48.9 in.), move the lift according to the illustration above (zigzag).

Locking Wheels

FreeSpan's wheels can be locked, if necessary. To lock wheels, step on the foot brake. Release the lock by pressing the lever up.

Care and Maintenance

For safe and trouble-free operation, a few routine procedures should be performed every day the lift system is used:

- Visually inspect the lift system and check for external damage or wear.
- Check the carriage function.
- Check possible Quick Release Hook safety-catch function.
- Ensure that locking handles are securely tightened.

Clean the lift regularly by wiping it with a damp cloth or waterbased surface disinfectants. **NOTE! Avoid regular use of cleaning agents that contain phenol or chlorine, since these can damage aluminium and polyamide material.**

Inspection

FreeSpan must be inspected at least once per year. Pay particular attention to parts that are subject to wear. Inspection must be performed according to the Liko service manual and by authorized personnel.

IMPORTANT

Repairs and maintenance may only be done by authorized Hill-Rom personnel using original spare parts.

Storage

The lift system must be stored at a temperature above the freezing point and at normal relative humidity (not exceeding 60%).

Service agreements

Hill-Rom invites you to sign a service agreement for regular maintenance and testing of your lift system. Liko's products are constantly being updated and refined. Hill-Rom reserve the right to change aspects of the products without prior notice. Contact your local Hill-Rom representative for updated information and advice.

Recycling

For instructions on how the FreeSpan lift system should be recycled, please visit our website www.liko.com.

Made in Sweden

Liko is quality certified according to ISO 9001 and environment certified according to ISO 14001.



www.hill-rom.com | www.liko.com